

Stunning and slaughter of ostriches

Steve Wotton^{a,*}, Julian Sparrey^b

^a*Division of Food Animal Science, Department of Clinical Veterinary Science, University of Bristol,
Langford House, Langford, Bristol BS40 5DU, UK*

^b*Silsoe Research Institute, Wrest Park, Silsoe, Bedfordshire MK45 4HS, UK*

Received 9 April 2001; received in revised form 21 June 2001; accepted 21 June 2001

Abstract

A study of the commercial stunning and slaughter of 783 ostriches in a Republic of South African abattoir revealed that a simple ostrich handling system, combined with a leg clamp applied during stunning current flow and operated by experienced ostrich slaughtermen, resulted in a humane, efficient slaughter process. It was estimated that an electrical stunning current in excess of 400 milliamps at 50 Hz AC, applied to the head only, would prevent recovery in more than 90% of the ostriches, when bled within 60 s from the start of stunning. The identification of rhythmic breathing movements indicate the first stages of recovery and is therefore an essential diagnostic 'tool' in recognising the effectiveness of the stunning treatment. The identification of rhythmic breathing movements in the ostrich after stunning is difficult because spinal reflexes, which produce contraction of limb muscles and result in almost rhythmic body movements could easily be confused with breathing movements. © 2002 Elsevier Science Ltd. All rights reserved.

Keywords: Ostrich; Electrical stunning; Voltage; Current; Impedance; Rhythmic breathing

1. Introduction

Pre-slaughter stunning, in relation to an animal, means any process which causes immediate loss of consciousness which lasts until death (MAFF, 1995a). Permitted pre-slaughter stunning methods for ostriches are (1) captive bolt pistol, (2) concussion, (3) electro-narcosis, and (4) exposure to carbon dioxide (Lambooij, 1998). Penetrative captive bolt stunning has been observed in the Republic of South Africa (RSA) by Church (1984), who was not convinced that the birds were rendered unconscious by either captive bolt or free bullet. The weight and movement of the bird makes the captive bolt an unsuitable method for stunning ostriches (Madeiros, 1994) and their relatively thin skull exacerbates the problem of achieving a concussed state. Guidance notes issued by MAFF (1995b) on the slaughter of ostriches state that there is not sufficient evidence in Great Britain to suggest that mechanical stunning

should not be used as a 'front line' method of stunning although its use as a back-up and for the emergency slaughter of ostriches is not disputed. Sales (1999) reports the use of electrical stunning methods in RSA and Israel, and Hewitt (1996) discusses the use of gaseous stunning methods for ostriches.

The growth of the ostrich industry in the UK has led to the requirement for commercial slaughter facilities. There is little published evidence of commercial practice that would meet the UK requirement for humane stunning and slaughter. Therefore, this reported study of a commercial processing plant in the Republic of South Africa (RSA) was undertaken. Until recently, a processing monopoly was held in the RSA by Klein Karoo Agricultural Co-operative, who were able to artificially manipulate prices. Deregulation has permitted competition from a number of relatively new companies of which one of the abattoirs visited (Abattoir A) was a primary mover. The major objective of this commercial trial was to determine whether the commercial stunning practices in RSA were adequate to ensure that irreversible loss of consciousness was achieved. Simultaneously, the welfare aspects of the transport, live-bird handling, stunning and slaughter was examined at Abattoir A.

* Tel.: +44-117-928-9237; fax: +44-117-928-9324.

E-mail address: steve.wotton@bris.ac.uk (S. Wotton).

2. Materials and methods

Following an initial appraisal of the normal operational procedure at Abattoir A, the following variables were recorded over a 7-working day period.

2.1. Variables recorded during the commercial trial

2.1.1. Bird sex

Birds were sexed by the presence of black feathering on the males and largely grey feathering on the females.

2.1.2. Current measurement

A Fluke 8060A True RMS multimeter was inserted in series with the output of the stunner control panel to provide a digital RMS display of stunning current. A Heme AC/DC current probe was clamped around the 'in-series' conductor and the induced current was digitally displayed on a 'Scopemeter' (Phillips PM97) to indicate the current profile.

The system was calibrated across a standard 820 Ω aluminium clad wirewound resistor. The stunner control unit was constant voltage in design, delivering 95 V under load (97.9 V open circuit) (Jarvis, RSA).

2.1.3. Stun duration

The stun duration was recorded as the total time of current application, whether a single application or a double stun. Comments were recorded when mis-applications took place.

2.1.4. Tong positioning

The stunning tongs used were modified pig tongs that were fitted with circular, cup-like electrodes (Fig. 1). Tong positioning was subjectively scored as:

1. eye to eye (with the circular electrodes probably surrounding, not in direct contact with, the eyes);
2. one eye and another area of the head; and
3. no eyes, tongs usually applied vertically.

2.1.5. Post stun convulsions (clonic activity)

The degree and extent of kicking movements that interfered with the ability to shackle the birds quickly and safely was scored from the initiation of the stun until the bird was on the hoist, where:

- 0 = no convulsions.
- 1 = mild convulsions.
- 2 = moderate convulsions.
- 3 = severe convulsions.

2.1.6. Stun to shackle time

The time in seconds was recorded between the start of stunning and successful execution of the shackling procedure.

2.1.7. Stun to stick time

The time in seconds was recorded between the start of stunning and the first appearance of blood from the sticking wound.

2.1.8. Heart function

Heart function was determined by auscultation.

2.1.9. Breathing movements

The presence of rhythmic breathing movements was determined by auscultation.

2.1.10. Nictitating membrane reflex

The presence of a nictitating membrane reflex was determined through corneal stimulation once the other tests had been performed.

The results were analysed by logistic regression. The effective current dose to give a 90% kill, as judged by the absence of rhythmic breathing movements, was found by back transformation and fiducial (confidence) limits on the effective dose were found by the application of Fieller's theorem (Genstat 5 Committee, 1993).

3. Results

The 'normal' processing procedure witnessed at Abattoir A was as follows: About 160 ostriches were slaughtered per day after an overnight recovery in a

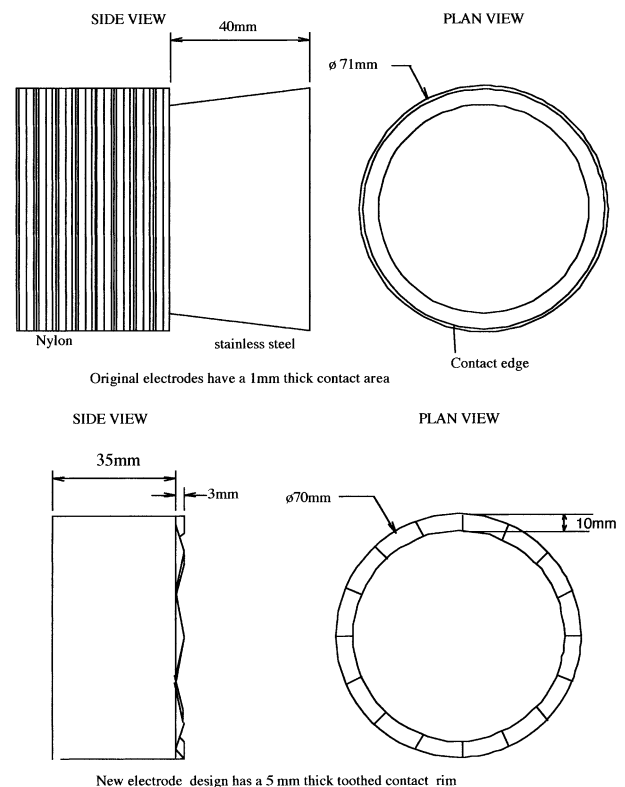

Fig. 1. Original electrodes and suggested improvements.

covered, open-sided, concrete-floored lairage, constructed of octagonal-shaped pens of tubular steel bars. Birds (15–20 per pen) had continuous access to water but were not fed.

The birds were approximately 14 months old, African Black Ostriches of approximately 95 kg live weight.

3.1. Bird arrival and lairage

Ostriches arrived at the abattoir by road in open-topped, railed-sided vehicles in groups of 10–20 birds with up to 90 birds on a single vehicle. Birds were not transported in wet or extremely hot weather, and where possible, they were loaded and transported at night to protect them from high ambient temperatures. Every effort was made to ensure that ostriches did not sit down or lose their footing during transport. It was reported that birds that do not remain standing are quickly trampled and killed through suffocation or neck dislocation and farm workers travel in each bird compartment on the vehicles, during transport, to prevent this from occurring.

Birds were unloaded at a horizontal unloading bay into a covered, but open-sided lairage. Lairage pens were octagonal in design, so as to prevent birds from being crushed in right-angled corners and the pen sides were of tubular steel to a height of 2 m.

Floors were of rough concrete with 2–4 cm wide gulleys every 30 cm in a chequer-board pattern to provide a non-slip surface for the birds. Water was provided in troughs that were external to the pens but easily accessible by the birds. Care had been taken to ensure that there were no rough edges or openings through which the birds could catch their heads. Gate fastenings were “ostrich-proof”. The lairage staff were experienced ostrich handlers and every effort was made to ensure the well being of the birds and the maintenance of a stress-free environment.

On arrival at the abattoir a number of birds were panting, showing signs of mild distress and all birds were lairaged overnight to allow them time to recover, during which they given free access to water but were not fed.

Ostriches were moved by the lairage staff in a calm, unhurried fashion. A high proportion (70%) of the value of the bird is in the hide. Any damage, for example kick mark scars, bruising or fresh wounds result in downgrading by the tannery therefore, the welfare of the ostrich was of prime importance to the abattoir staff and birds that arrived at the abattoir with fresh wounds were generally returned to the farm to heal. Ostriches were led by an operative moving ahead of the birds calling encouragement, occasionally reinforced by the use of the arm and hand to mimic an ostrich neck/head to entice them forward. Another operative followed behind the group being moved. The use of excessive

force or, any coercive goad was not witnessed. The ostriches, although generally unused to being handled, responded well to this treatment. During the 8 days spent at this plant, we only witnessed a single attempt by an ostrich to kick a stunning pen operative. Operatives were familiar with the warning signs of an impending attack and protection was afforded by the presence of a solid gate-partition (Fig. 2).

3.2. Bird movement to the point of stun

Groups of 15–20 birds were moved from the lairage through a 1.7 m wide race into a holding pen (3.5×3.5 m). Subgroups of about six birds were moved from the holding pen through a ‘single-bird race’ (Fig. 2) to the entrance of the stunning area, which was the point of stun. A single operative guided the individual bird into position through the manipulation of the tail feathers from behind. Once the bird was correctly positioned, a second operative wearing rubber gloves, prevented any further forward movement by standing in front of the bird. He grasped the bird by holding the beak and brought the head down into a position easily accessible to the stunning operative.

3.3. Stunning procedure

A third operative applied 95 V (Jarvis, RSA) to the head of the bird via hand held scissor tongs that were adapted from pig tongs. The tongs contained modified

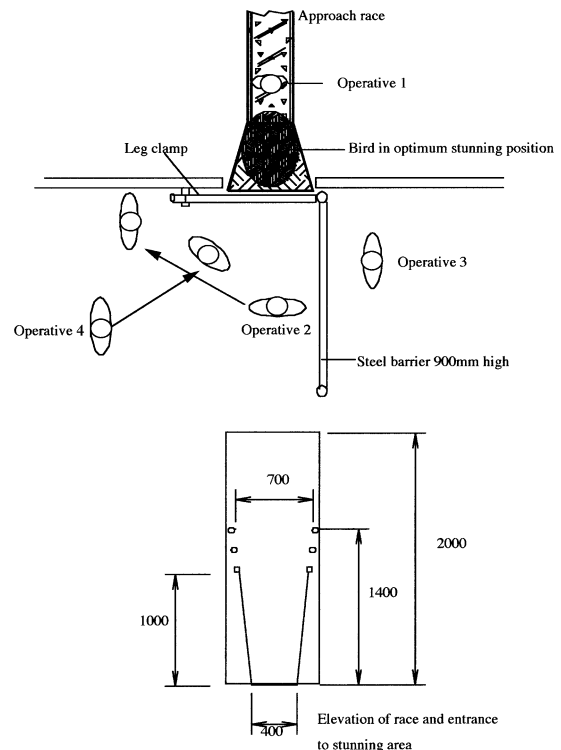

Fig. 2. Stunning area and approach race.

electrodes that were cup-shaped, 70 mm in diameter with a rim contact area approximately 1 mm wide. The electrodes were, on examination, tarnished with a build-up of 'grime' and carbon that would have reduced overall conductivity significantly. The control unit was set to deliver a timed stun (1–12 s) at 95 V initiated by a tong switch. However, the timer had failed and the switch on the tongs was subsequently disconnected leaving the electrodes constantly live.

3.4. Leg clamping

Following the initiation of the stun and while the current was still applied, a fourth operative rocked the bird backwards, assisted by the first operative from behind. This enabled the application of a leg clamp (Fig. 2) designed and constructed by abattoir staff. The clamp, applied by the second operative, enabled the legs to be fixed at the tarso-metatarsal bone, thus restraining the bird sufficiently to permit shackling.

3.5. Shackling

At this point the stunning tongs were removed and the fourth operative ring/chain shackled the bird via the big toes and attached the shackle to a chain hoist. The bird was hoisted onto a 3.4 m overhead rail, hooked on a trolley and manually conveyed to the point of slaughter where a high neck cut was performed. The birds were allowed to bleed for approximately 14 min in a bleeding area before manual plucking took place.

Data were obtained from the slaughter of 783 ostriches over a 7-day period. In 429 birds a complete record was obtained, whilst in the remaining 354 birds the throughput demands of the plant limited the obtainable data to a record of stunning current, voltage and tong positioning. An appraisal of 'normal' practice revealed that the regular Jarvis stunner employed in the plant, delivered 95 V, at 50 Hz AC (setting 90/2) under bird load. The stunner was also capable of generating 180 and 240 V, respectively.

The variation in stunning voltage and electrode condition evaluated during the trial and the effect of this variation on average stunning current flow is shown in Table 1.

The variation in stunning tong position seen over all stunning treatments was as follows:

- eye to eye—59% of stun applications;
- one eye and another area of the head—38% of stun applications;
- no eyes, tongs usually applied vertically—3% of stun applications.

Although there was a reduction in the number of birds showing signs of recovery for the vertical application, the number of birds within this treatment group was small and gave an unreliable estimate of the ED 90% (estimated dose for a 90% occurrence of effective stunning). There was no significant difference between the lateral application positions.

The average (\pm S.D.) stun duration across all treatment groups was 10 s (\pm 2.5). Changes in the stun duration had no significant effect on the likelihood of recovery. The average (\pm S.D.) score for the degree of post stun convulsions was 1.366 (\pm 0.669). This represents a score between mild and moderately severe and reflects the effectiveness of the system employed.

Stun to shackle times ranged from 11 to 51 s with a mean value of 17 s. The average (\pm S.D.) overall stun to stick time was 46 s (\pm 6.1), with a range between 36 and 84 s. Increasing the stun to stick time appeared to increase the chance of recovery.

Eighteen per-cent of ostriches exhibited a positive nictitating membrane reflex and 11% of birds showed a return of rhythmic breathing movements. However, a comparison of the two brain stem reflexes produced a poor correlation ($r=0.442$) and previous studies have shown the return of rhythmic breathing movements to be a better indicator of the consequent return of consciousness than the nictitating membrane reflex (Anil, 1991).

Cardiac function was found to be normal in all birds, however a discernible rhythm was occasionally absent initially, presumably due to a prolonged period of bradycardia produced by vagal stimulation by the stunning current during the head-only application.

A careful examination of the vessels severed at slaughter revealed that the complete ventral neck cut employed at the plant, severed all soft tissues ventral to the spine including both carotid arteries, both jugular veins, the trachea and oesophagus. The cut was carried

Table 1
The effect of stunning voltage and electrode condition on average current flow

Stunning voltage	Tarnished electrodes	Clean electrodes	Saline sponge added
95	262 mA ($n=401$)	309 mA ($n=309$)	887 mA ($n=6$)
180	822 mA ($n=61$)		
90 ^a	99 mA ($n=4$)		

^a 'Current limited' to 118 mA.

out high on the neck close to the head. Blood loss was immediate and profuse and continued for a considerable period (approximately 600–720 s). We were unable to find any evidence in the literature, and there was little practical evidence to suggest that the vertebral arteries in the ostrich contribute significantly to cerebral perfusion as there was insignificant flow from the rostral cut end of the jugular veins. However, a detailed anatomical dissection is required to confirm this observation.

4. Discussion

Preliminary analysis of the results suggested that as stunning current was increased, the incidence of birds showing signs of recovery as indicated by a return of rhythmic breathing movements, before they died through exsanguination, decreased. Further analysis of the data suggested that there was an increase in the number of birds returning to rhythmic breathing movements as the stun to stick interval increased. The ostrich must be killed by exsanguination before resumption of consciousness can potentially occur in order to comply with current legislation (MAFF, 1995a). Increases in the length of the stun to stick interval as recorded during this commercial trial would be expected to produce evidence of returning consciousness as identified by the return of rhythmic breathing movements.

The data from the study provided evidence that the minimum stunning current that would result in 90% of the ostriches being effectively stunned was 312 mA, with a 90% confidence interval of 236 to 538 mA. The following factors contributed to the wide confidence interval for the 90% effective current dose (ED 90):

In order to determine the effective dose at the limits of a distribution (i.e. towards 0 or 100% effective) requires a far greater number of experimental animals than identifying the effective dose at 50%. Thus, a very large number of animals would be required for a narrow confidence interval at ED90.

The measurement of current flow was an average taken over the whole stunning period (10 s) and did not account for the variations that would occur in the current profile. In addition, the average current flow might not be representative of the spreading current field penetration of the head of the ostrich and its ability to stimulate neural tissue.

Previous studies have shown that variation between animals can be very large.

In conclusion, within the accuracy of this study, it is suggested that a minimum current of 400 mA would induce an effective stun in greater than 90% of ostriches, provided that the stun to stick interval did not exceed 60 s.

An effective electrical stun will produce brain dysfunction and remove the higher control over spinal

reflexes; this is expressed as uncoordinated physical activity (kicking). Therefore, if the slaughter process is delayed because of vigorous physical activity, there is a likelihood that the animal may recover either before it is stuck or during the early stages of exsanguination. An average kicking score of 1.366 reflects a degree of convulsion closer to mild than moderate and did not seem to affect the time between stun start and stick.

It was reported that RSA legislation requires that the maximum permitted time between the end of current flow and the start of exsanguination is 60 s. The average time between stun start and exsanguination recorded during the trial was 46 s (range 36–84).

An initial observation of the birds at the point of stick and during early blood loss at the outset of the study, indicated that recovery of rhythmic breathing movements and hence the possible return of consciousness was commonplace. However, a closer examination through the use of a stethoscope to identify inspired air movement showed that spinal reflexes that produced contraction of limb muscles resulted in an almost rhythmic body movement that was easily confused with breathing movements. Rhythmic breathing movements, when present, tended to be very short lasting. A complete ventral neck cut resulted in a rapid loss of brain-stem reflexes to such an extent that there was little correlation between the return of rhythmic breathing and a positive nictitating membrane reflex. The expression of a return of rhythmic breathing movements was cut short by exsanguination and as the presence of a nictitating reflex was tested sequentially, after the presence of rhythmic breathing movements, the reflex was probably lost before assessment could take place.

The ostrich behaves physiologically more like poultry than red meat species, because relatively low head-only stunning current applications produce a prolonged period of anaesthesia. In turkeys, head-only stunning at 399 mA (110 V) was found to produce a humane stunning/slaughter method when combined with exsanguination within 15 s (Gregory and Wotton, 1991). The average stun to stick interval recorded during the present trial was 46 s, therefore a similar current when applied to an ostrich produced a longer period of unconsciousness. The thickness of the skull, and size of the eyes and optic nerve, provide a possible clue to perhaps an increase in current penetration of the brain in the ostrich, that may account for the disparity in recovery times. However, the speed of loss of brain function following exsanguination requires further investigation.

The electrode design, although very effective at maintaining contact with the stunned bird as it went tonic, had a very small contact area with the bird's head resulting in an exaggerated heating effect at relatively low current levels. This heating effect would enhance a build-up of carbon deposits that would very quickly increase the impedance between the electrodes and the

skin, reducing current flow. An increase in current flow was demonstrated by cleaning the existing electrodes. An increase in electrode surface area, as demonstrated in Fig. 1, would produce an increase in current flow at a similar voltage and reduce the build-up of carbon on the electrodes. Nevertheless, regular cleaning of stunning tong electrodes would reduce the variation in applied current between birds. It is suggested that an increase in voltage to 110 V combined with the improved electrode design would produce a higher current on average, without compromising operator safety. The trial use of saline-soaked sponges produced a threefold increase in current amplitude; however, only six birds were stunned before an internal short circuit in the tongs was detected.

An improvement in electrode design with the inclusion of saline sponges, combined with a marginal increase in voltage to 110 V should meet the requirement for a minimum current of 400 mA. A switch on the tongs operating at low voltage or an electronic switch that measured the impedance of the load, could trigger a timing circuit to deliver a 10 s stun, that should be sufficient to clamp the legs. Current sensing circuitry within the control unit could alert the operator when at least 400 mA had been delivered. Thus the stunning tong operator would be made aware of whether sufficient or insufficient current is applied such that remedial action in the form of cleaning with a powered wire brush can be used to reduce impedance between the electrodes and the skin, and hence, increase the current flow.

Acknowledgements

The authors wish to thank the Ministry of Agriculture, Fisheries and Food who funded this work and Dr. R. White (Silsoe Research Institute) and Dr. T. G. Knowles (DFAS, University of Bristol) for their assistance with the statistical analysis.

References

- Anil, M. H. (1991). Studies on the return of physical reflexes in pigs following electrical stunning. *Meat Science*, 30, 13–21.
- Church, N. (1984). *A report into welfare aspects of farmed ostriches*. Agricultural and Development Advisory Service.
- Genstat 5 Committee (1993). *Genstat 5 Release 3 Reference Manual*. Oxford Scientific Publications, Oxford University Press: Oxford (p. 416).
- Gregory, N. G., & Wotton, S. B. (1991). Effect of electrical stunning on somatosensory evoked responses in the turkey's brain. *British Veterinary Journal*, 147, 270–274.
- Hewitt, L. (1996). *Welfare aspects of the commercial slaughter of ostriches*. MSc thesis, University of Bristol, UK.
- Lambooi, E. (1998). Captive needle improves ostrich meat quality. *Meat International*, 8, 7 733–35.
- Madeiras, C. (1994). BDOA Veterinary representative visit to the only EEC approved emu and ostrich abattoir. *Ostrich News*, 3, 3–11.
- MAFF. (1995a). *The welfare of animals (slaughter or killing) regulations*. London: HMSO.
- MAFF. (1995b). *Guidance on the slaughter of ostriches—welfare (welfare of animals (slaughter or killing) regulations)*. London: HMSO.
- Sales, J. (1999). Slaughter and Products, Chapter 10. The ostrich biology, production and health. In D. C. Deeming (Ed.), (pp. 232–233). CABI Publishing.